

Otpornost R u kolu naizmjenične struje

- Pretpostavimo da je **otpornik R** priključen na prostoperiodični napon:

$$u(t) = U_m \sin(\omega t)$$

- Po Omovom zakonu pad napona na otporniku je:

$$u_R(t) = R \cdot i(t)$$

- Struja kroz otpornik ima vrijednost:

$$i_R(t) = \frac{U_m}{R} \sin(\omega t) = I_m \sin(\omega t)$$

Struja kroz otpornik $i_R(t)$ u fazi je sa naponom na otporniku $u_R(t)$

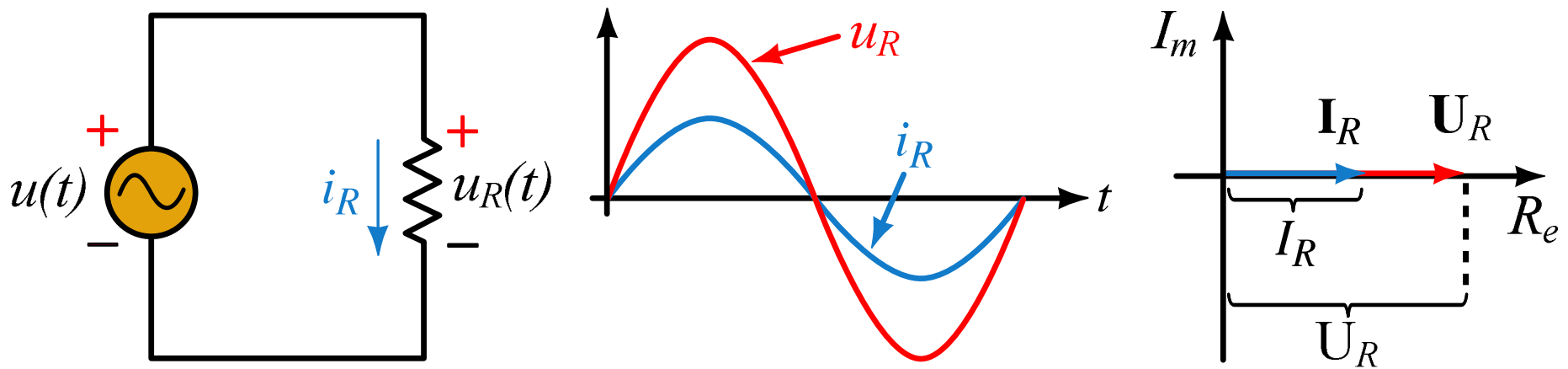

Otpornost R u kolu naizmjenične struje

Primjer:

EXAMPLE 16–11 For the circuit of Figure 16–18(a), if $R = 5 \Omega$ and $i_R = 12 \sin(\omega t - 18^\circ) \text{ A}$, determine v_R .

Solution $v_R = Ri_R = 5 \times 12 \sin(\omega t - 18^\circ) = 60 \sin(\omega t - 18^\circ) \text{ V}$. The waveforms are shown in Figure 16–20.

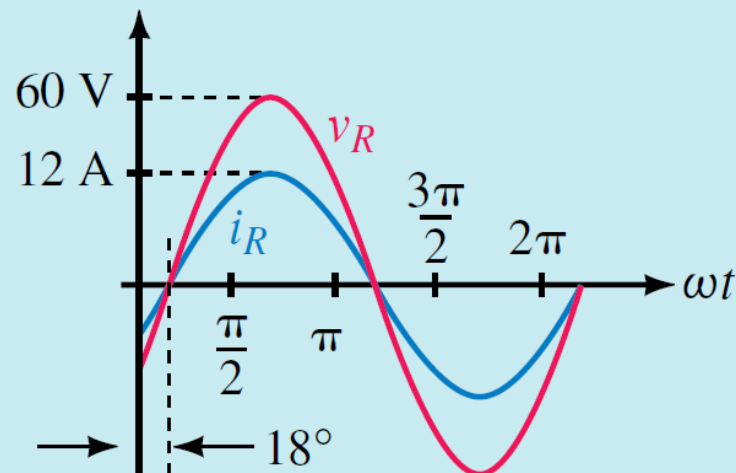

FIGURE 16–20

Otpornost R u kolu naizmjenične struje

Primjer:

1. If $v_R = 150 \cos \omega t$ V and $R = 25 \text{ k}\Omega$, determine i_R and sketch both waveforms.
2. If $v_R = 100 \sin(\omega t + 30^\circ)$ V and $R = 0.2 \text{ M}\Omega$, determine i_R and sketch both waveforms.

Answers:

1. $i_R = 6 \cos \omega t$ mA. v_R and i_R are in phase.
2. $i_R = 0.5 \sin(\omega t + 30^\circ)$ mA. v_R and i_R are in phase.

Zavojnica L u kolu naizmjenične struje

- Pretpostavimo da je **zavojnica L** priključena na prostoperiodični napon:

$$u(t) = U_m \sin(\omega t)$$

- Napon zavojnice $u_L(t)$ i struja zavojnice $i_L(t)$ povezani su izrazom:

$$u_L(t) = L \frac{di_L}{dt}$$

- Struja zavojnice $i_L(t)$ je:

$$i_L(t) = \frac{1}{L} \int U_m \sin(\omega t) = -\frac{U_m}{\omega L} \cos(\omega t)$$

$$i_L(t) = I_m \sin\left(\omega t - \frac{\pi}{2}\right)$$

Struja zavojnice $i_L(t)$ fazno zaostaje za ugao $\pi/2$ u odnosu na napon zavojnice $u_L(t)$

Napon na zavojnici $u_L(t)$ fazno prednjači za ugao $\pi/2$ u odnosu struju zavojnice $i_L(t)$

Zavojnica L u kolu naizmjenične struje

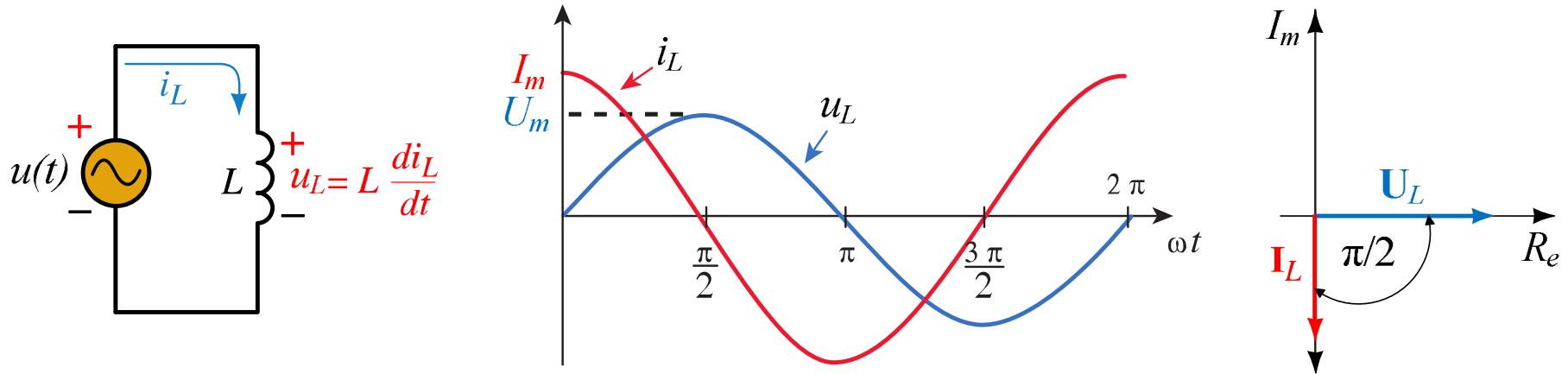

- Maksimalna vrijednosti napona U_L i struje zavojnice I_L povezane su izrazom:
- Veličina ωL naziva se induktivna reaktansa i označava se sa X_L i izražava se u omima (Ω)
- Prema Omovom zakonu važe jednakosti:

$$\frac{U_m}{I_m} = \omega L$$

$$X_L = \omega L [\Omega]$$

$$I_L = \frac{U_L}{X_L}; \quad U_L = I_L \cdot X_L; \quad X_L = \frac{U_L}{I_L}$$

Zavojnica L u kolu naizmjenične struje

Induktivna reaktansa X_L predstavlja otpor zavojnice proticanju (promjeni) struje I_L kroz sebe.

- Pošto je $X_L = \omega L = 2\pi f L$ može se zaključiti da je vrijednost induktivne reaktanse direktno proporcionalna frekvenciji f
- Ako se frekvencija udvostruči udvostruči se i induktivna reaktansa i obrnuto

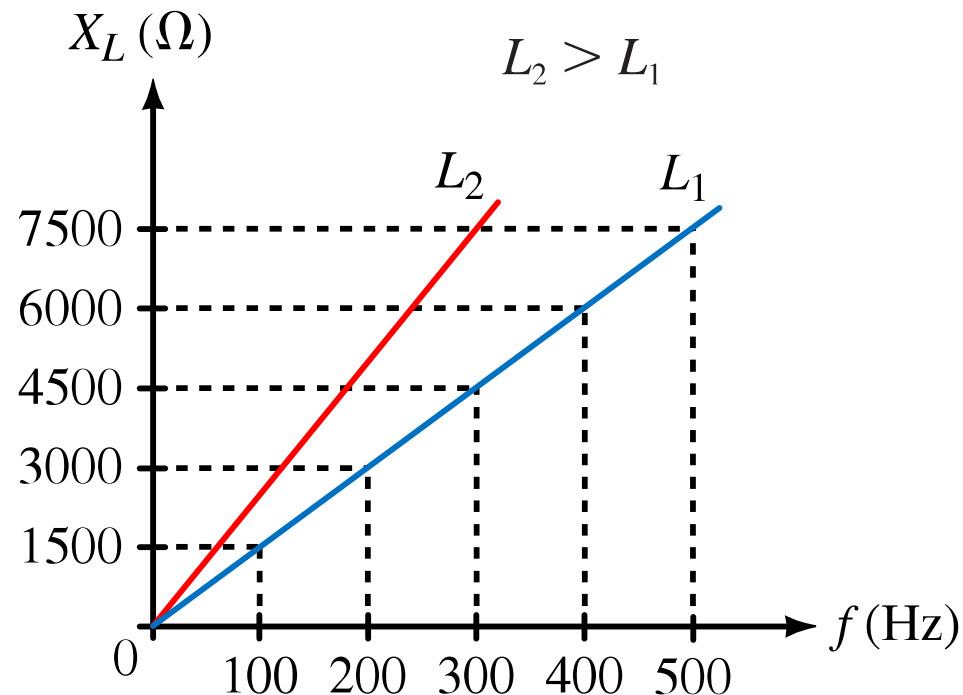

Zavojnica L u kolu naizmjenične struje

Primjer:

 **EXAMPLE 16–12** The voltage across a 0.2-H inductance is $v_L = 100 \sin(400t + 70^\circ)$ V. Determine i_L and sketch it.

Solution $\omega = 400$ rad/s. Therefore, $X_L = \omega L = (400)(0.2) = 80 \Omega$.

$$I_m = \frac{V_m}{X_L} = \frac{100 \text{ V}}{80 \Omega} = 1.25 \text{ A}$$

The current lags the voltage by 90° . Therefore $i_L = 1.25 \sin(400t - 20^\circ)$ A as indicated in Figure 16–25.

Zavojnica L u kolu naizmjenične struje

Primjer:

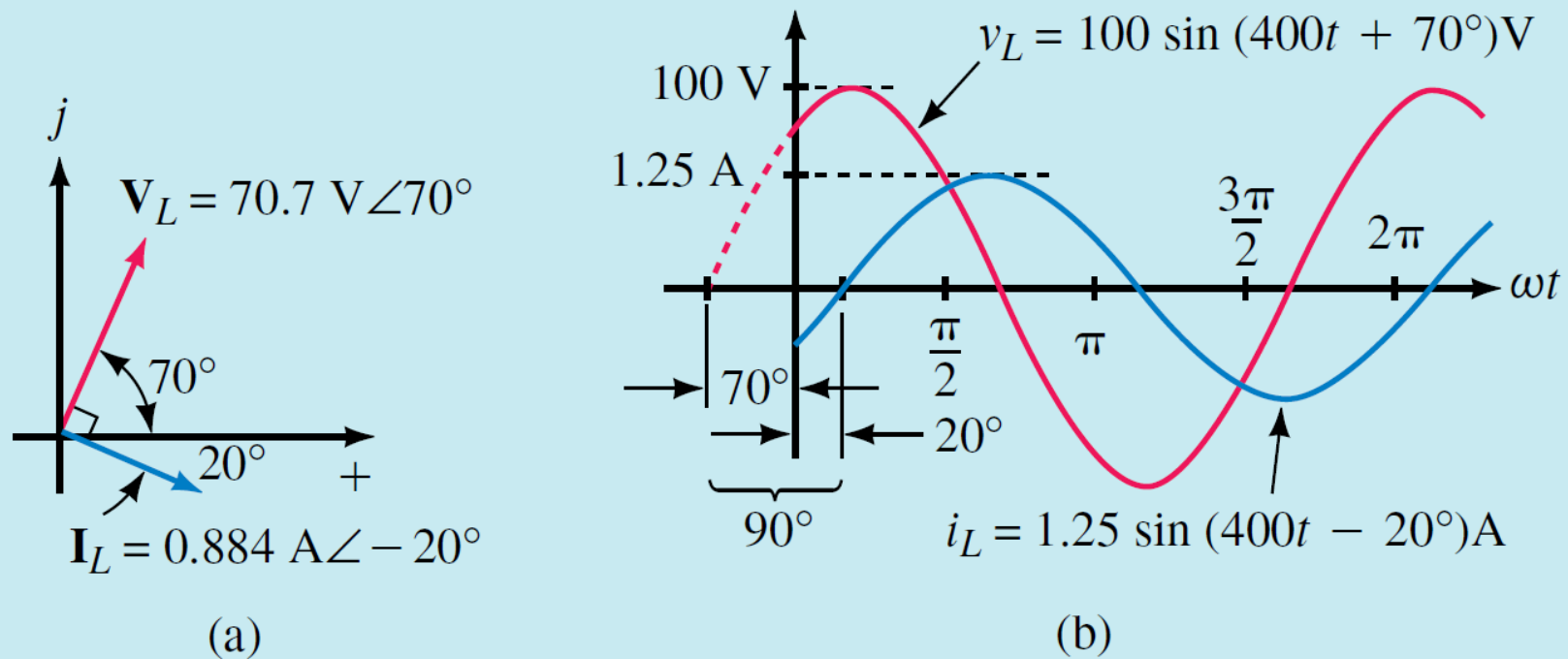



FIGURE 16–25 With voltage V_L at 70° , current I_L will be 90° later at -20° .

Zavojnica L u kolu naizmjenične struje

Primjer:

 **EXAMPLE 16–13** The current through a 0.01-H inductance is $i_L = 20 \sin(\omega t - 50^\circ)$ A and $f = 60$ Hz. Determine v_L .

Solution

$$\omega = 2\pi f = 2\pi(60) = 377 \text{ rad/s}$$

$$X_L = \omega L = (377)(0.01) = 3.77 \ \Omega$$

$$V_m = I_m X_L = (20 \text{ A})(3.77 \ \Omega) = 75.4 \text{ V}$$

Voltage leads current by 90° . Thus, $v_L = 75.4 \sin(377t + 40^\circ)$ V as shown in Figure 16–26.

Zavojnica L u kolu naizmjenične struje

Primjer:

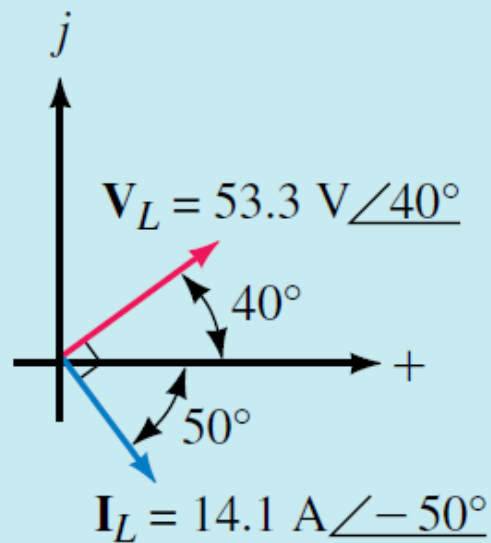

(a)

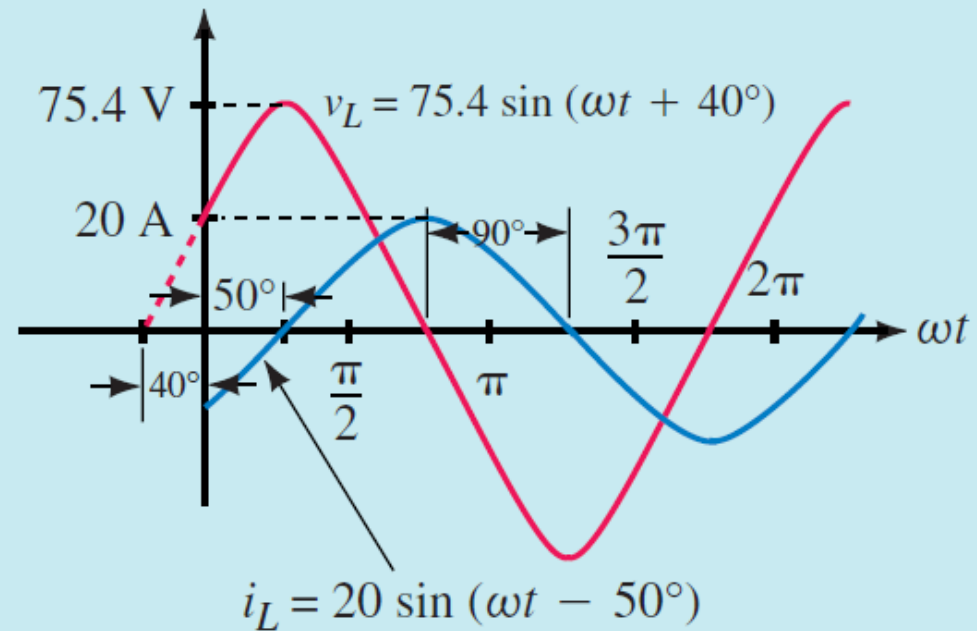

(b)

FIGURE 16-26

Zavojnica L u kolu naizmjenične struje

Primjer:

1. Two inductances are connected in series (Figure 16–27). If $e = 100 \sin \omega t$ and $f = 10$ kHz, determine the current. Sketch voltage and current waveforms.

FIGURE 16–27

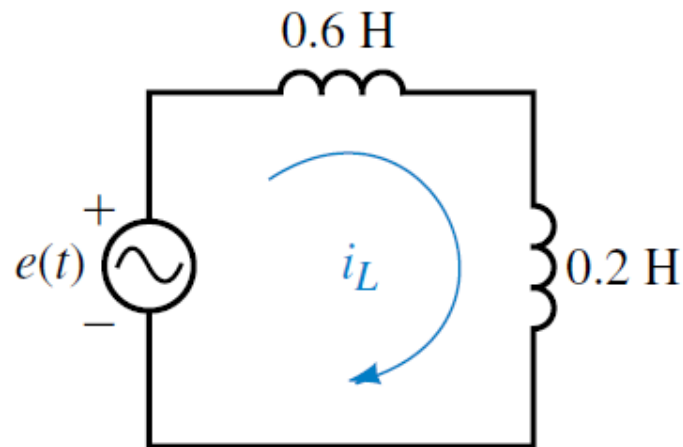

2. The current through a 0.5-H inductance is $i_L = 100 \sin(2400t + 45^\circ)$ mA. Determine v_L and sketch voltage and current phasors and waveforms.

Zavojnica L u kolu naizmjenične struje

Primjer:

Answers:

1. $i_L = 1.99 \sin(\omega t - 90^\circ)$ mA. Waveforms same as Figure 16–24.
2. $v_L = 120 \sin(2400t + 135^\circ)$ V. See following art for waveforms.

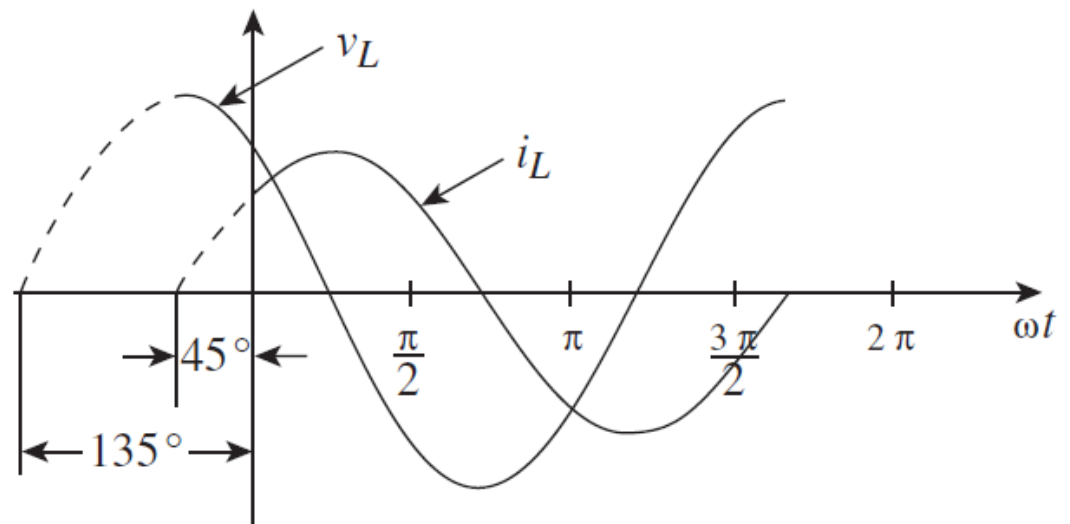
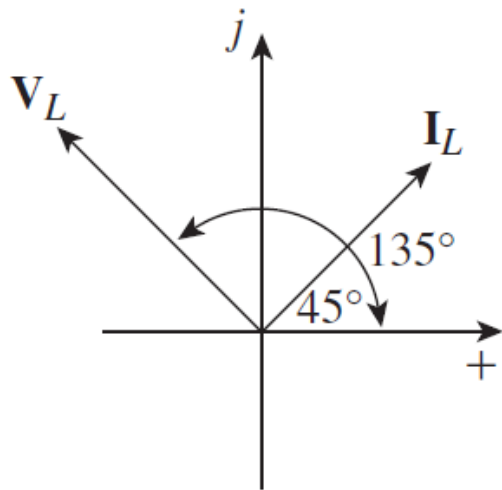

Kondenzator C u kolu naizmjenične struje

- Pretpostavimo da je **kondenzator C** priključen na prostoperiodični napon:

$$u(t) = U_m \sin(\omega t)$$

- Struja kondenzatora $i_C(t)$ i napon kondenzatora $u_C(t)$ povezani su izrazom:

$$i_C(t) = C \frac{du_C}{dt}$$

- Struja kondenzatora $i_C(t)$ je:

$$i_C(t) = C \frac{d}{dt} [U_m \sin(\omega t)] = \omega C \cdot U_m \cos(\omega t)$$

$$i_C(t) = I_m \sin\left(\omega t + \frac{\pi}{2}\right)$$

Struja kondenzatora $i_C(t)$ fazno prednjači za ugao $\pi/2$ u odnosu na napon kondenzatora $u_C(t)$

Napon kondenzatora $u_C(t)$ fazno kasni za ugao $\pi/2$ u odnosu struju kondenzatora $i_C(t)$

Kondenzator C u kolu naizmjenične struje

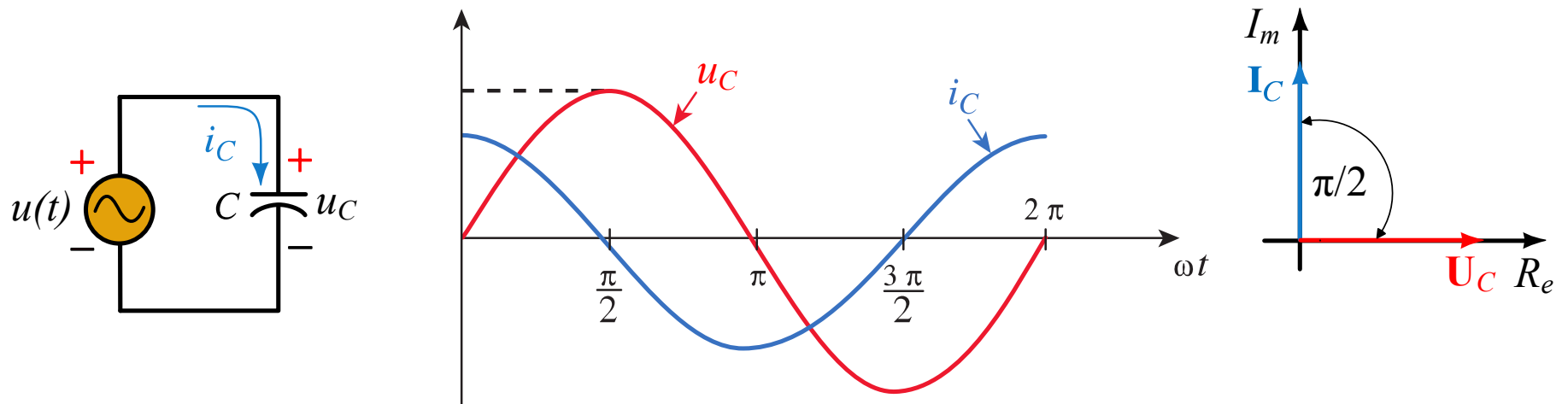

- Maksimalna vrijednosti napona U_C i struje kondenzatora I_C povezane su izrazom:
- Veličina $1/\omega C$ naziva se kapacitivna reaktansa, označava se sa X_C i izražava se u omima (Ω)
- Prema Omovom zakonu važe jednakosti:

$$\frac{U_m}{I_m} = \frac{1}{\omega C}$$

$$X_C = \frac{1}{\omega C} [\Omega]$$

$$I_C = \frac{U_C}{X_C}; \quad U_C = I_C \cdot X_C; \quad X_C = \frac{U_C}{I_C}$$

Kondenzator C u kolu naizmjenične struje

Kapacitivna reaktansa X_C predstavlja otpor kondenzatora promjeni napona U_C na svojim krajevima

- Pošto je $X_C = 1/\omega C = 1/2\pi f C$ može se zaključiti da je vrijednost kapacitivne reaktanse obrnuto proporcionalna frekvenciji f
- Pri većim frekvencijama f manja je kapacitivna reaktansa X_C i obrnuto
- U jednosmjernim kolima ($f=0$) kapacitivna reaktansa je beskonačna

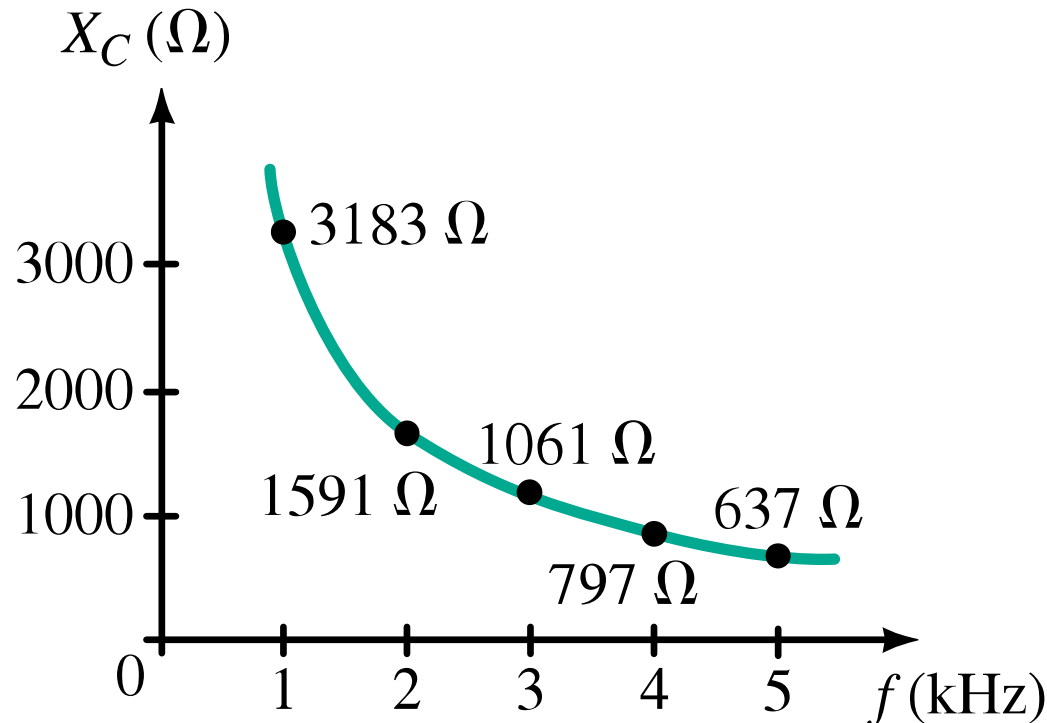

Kondenzator C u kolu naizmjenične struje

Primjer:

 **EXAMPLE 16-14** The voltage across a $10\text{-}\mu\text{F}$ capacitance is $v_C = 100 \sin(\omega t - 40^\circ)$ V and $f = 1000$ Hz. Determine i_C and sketch its waveform.

Solution

$$\omega = 2\pi f = 2\pi(1000 \text{ Hz}) = 6283 \text{ rad/s}$$

$$X_C = \frac{1}{\omega C} = \frac{1}{(6283)(10 \times 10^{-6})} = 15.92 \Omega$$

$$I_m = \frac{V_m}{X_C} = \frac{100 \text{ V}}{15.92 \Omega} = 6.28 \text{ A}$$

Since current leads voltage by 90° , $i_C = 6.28 \sin(6283t + 50^\circ)$ A as indicated in Figure 16-32.

Kondenzator C u kolu naizmjenične struje

Primjer:

Since current leads voltage by 90° , $i_C = 6.28 \sin(6283t + 50^\circ)$ A as indicated in Figure 16–32.

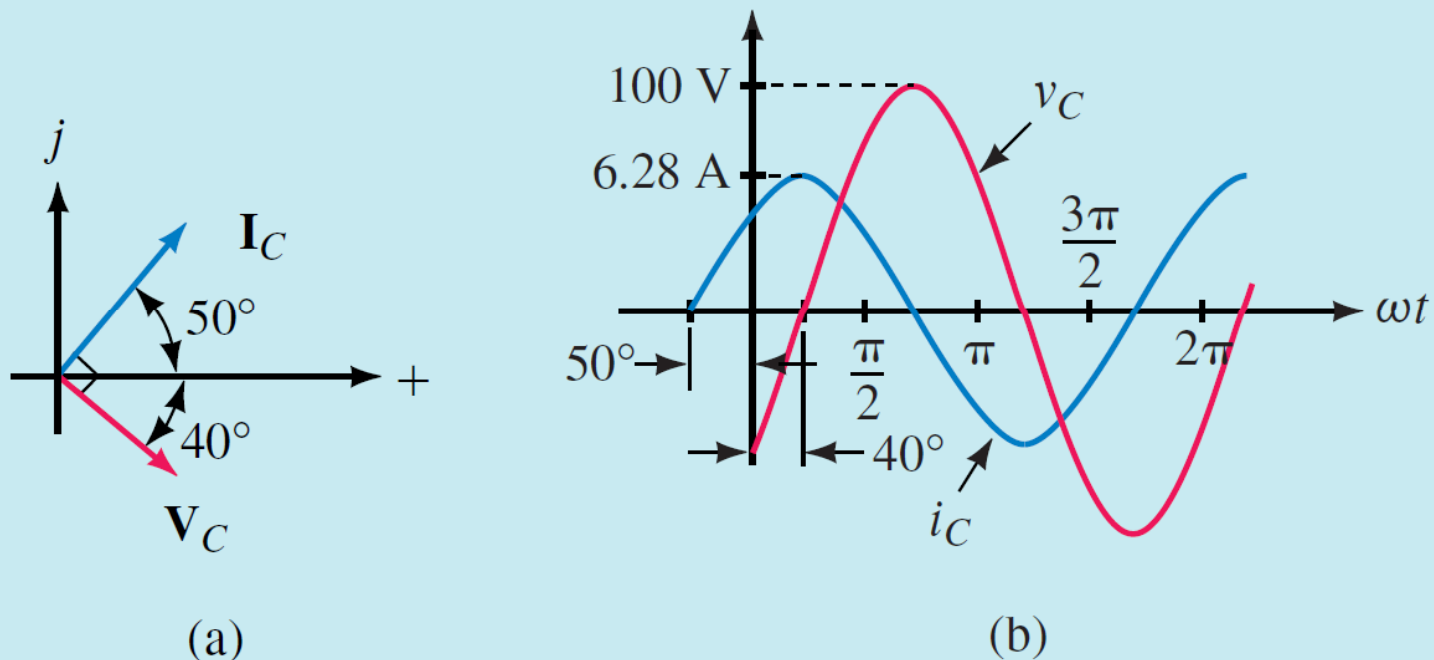



FIGURE 16–32 Phasors are not to scale with waveform.

Kondenzator C u kolu naizmjenične struje

Primjer:

 **EXAMPLE 16–15** The current through a $0.1\text{-}\mu\text{F}$ capacitance is $i_C = 5 \sin(1000t + 120^\circ)$ mA. Determine v_C .

Solution

$$X_C = \frac{1}{\omega C} = \frac{1}{(1000 \text{ rad/s})(0.1 \times 10^{-6} \text{ F})} = 10 \text{ k}\Omega$$

Thus, $V_m = I_m X_C = (5 \text{ mA})(10 \text{ k}\Omega) = 50 \text{ V}$. Since voltage lags current by 90° , $v_C = 50 \sin(1000t + 30^\circ)$ V. Waveforms and phasors are shown in Figure 16–33.

Kondenzator C u kolu naizmjenične struje

Primjer:

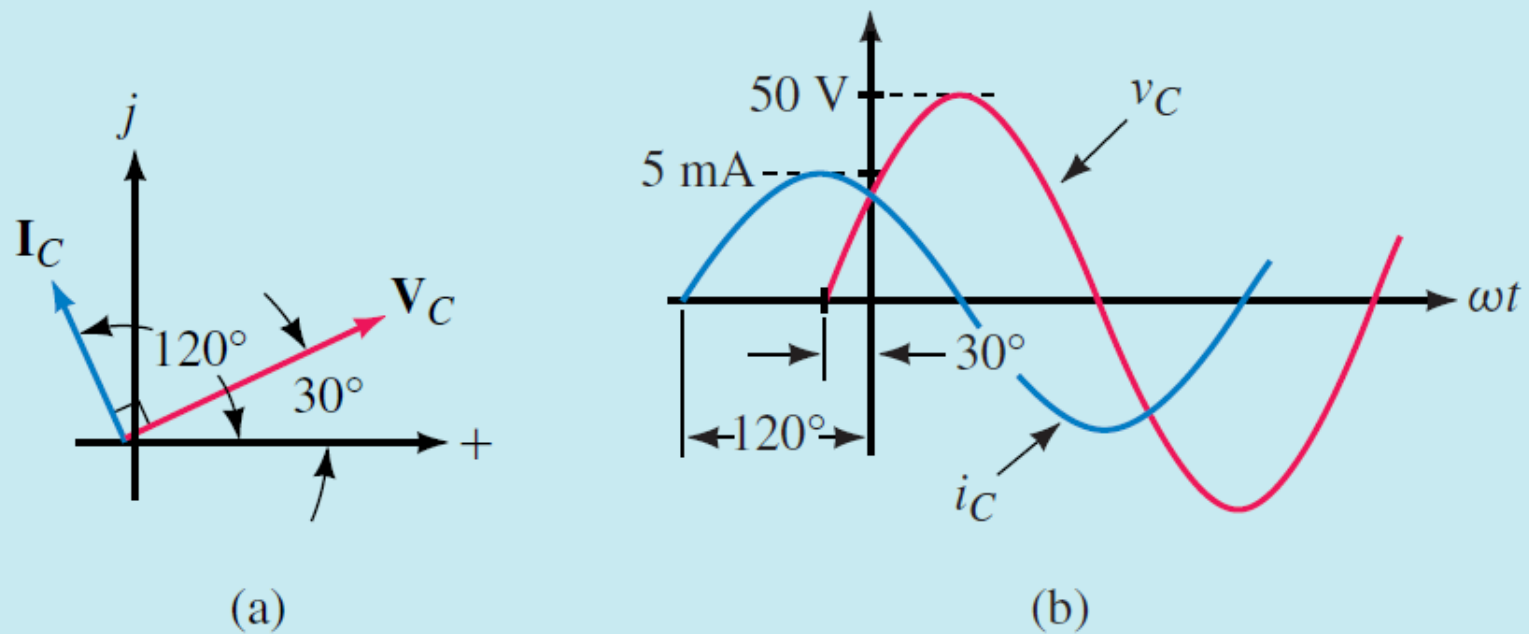

FIGURE 16-33 Phasors are not to scale with waveform.

Kondenzator C u kolu naizmjenične struje

Primjer:

Two capacitances are connected in parallel (Figure 16–34). If $e = 100 \sin \omega t$ V and $f = 10$ Hz, determine the source current. Sketch current and voltage phasors and waveforms.

FIGURE 16–34

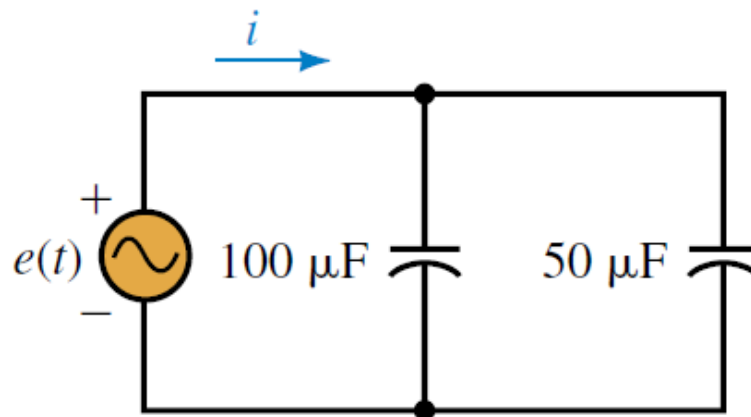

Answer: $i = 0.942 \sin(62.8t + 90^\circ) = 0.942 \cos 62.8t$ A
See Figure 16–29(b) and (c).

Pojam impedanse Z

- Mjera opiranja elemenata kola R,L i C proticanju naizmjenične struje u fazorskom domenu označena je kao **impedansa Z**
- Pošto se fazori predstavljaju kompleksnim brojevima to je i impedansa kompleksan broj
- **Modul impedanse Z** jednak je količniku efektivnih vrednosti napona i struje potrošača
- **Argument impedanse θ°** jednak je faznoj razlici napona i struje potrošača

$$\bar{Z} = \frac{\bar{U}}{\bar{I}} [\Omega]$$

$$\bar{Z} = \frac{\bar{U}}{\bar{I}} = \frac{U}{I} = Z \angle \theta^\circ$$

$$Z = \frac{U}{I}$$

$$\theta = \arctg \frac{I_m}{R_e}$$

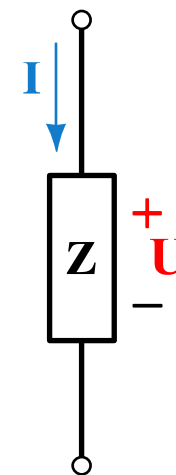

Grafička prezentacija impedanse Z

- Impedansa Z se može rastaviti na realni i imaginarni dio:
- Realni dio impedanse Z naziva se rezistansa R :
- Imaginarni dio impedanse naziva se reaktansa X :
- U algebarskom, eksponencijalnom i trigonometrijskom obliku izrazi za kompleksnu impedansu glase:

$$\bar{Z} = R + jX$$

$$R = \operatorname{Re}\{\bar{Z}\}$$

$$X = \operatorname{Im}\{\bar{Z}\}$$

$$\bar{Z} = R + jX = Ze^{j\theta} = Z \cos \theta + jZ \sin \theta$$
$$R = Z \cos \theta, \quad X = Z \sin \theta$$
$$Z = \sqrt{R^2 + X^2}$$
$$\theta = \operatorname{arctg} \frac{X}{R}$$

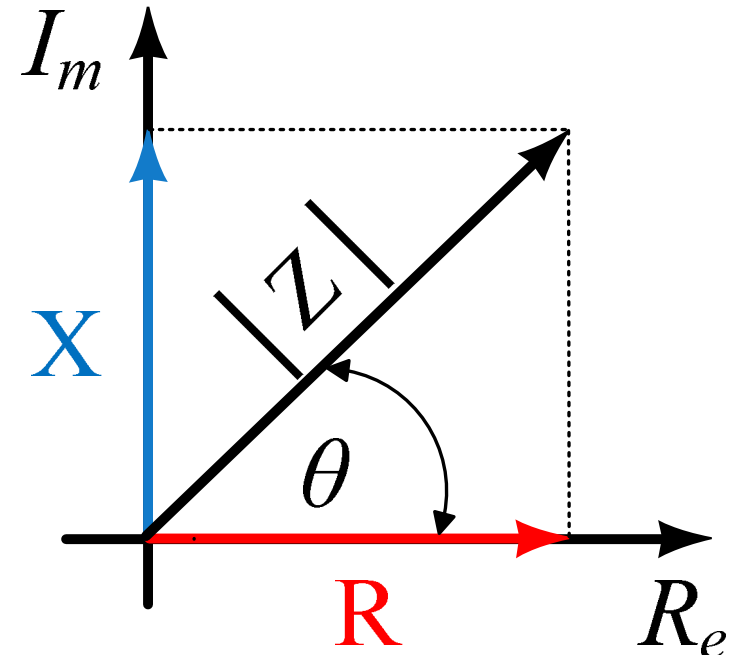

Predstavljanje otpornosti R kao impedanse

- Kod otpornosti R napon U_R i struja I_R su u fazi tj. $\theta=0^\circ$
- Ako napon ima neki početni ugao φ isti taj ugao će imati i struja

- Za impedansu Z_R u možemo napisati:

$$\overline{Z}_R = \frac{\overline{U}_R}{\overline{I}_R} = \frac{U_R \angle \varphi}{I_R \angle \varphi} = \frac{U_R}{I_R} \angle 0^\circ = R$$

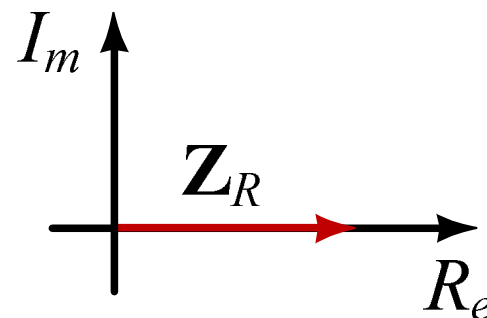
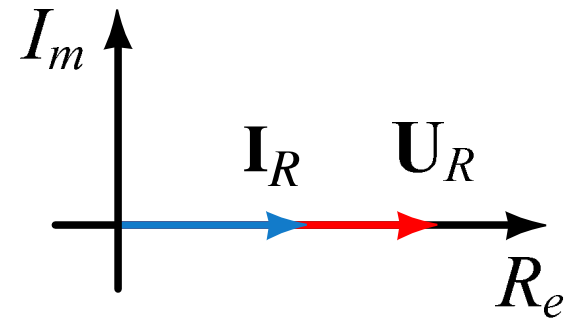
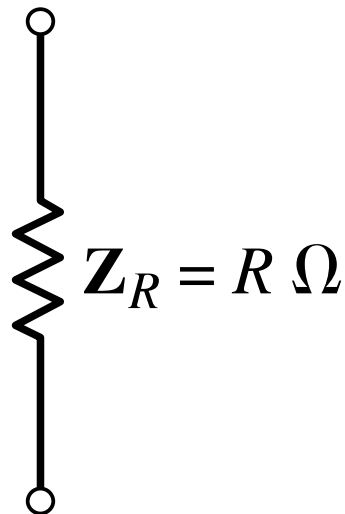
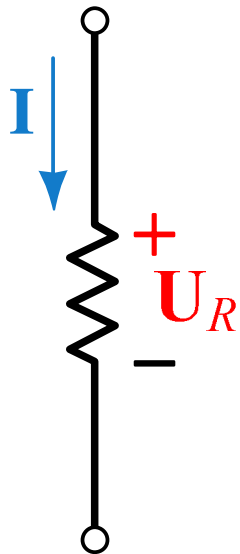

Predstavljanje zavojnice L kao impedanse

- Kod zavojnice L napon U_L prednjači struji I_L za ugao $\theta=90^\circ$
- Ako pretpostavimo da napon zavojnice U_L ima početni ugao $\varphi_U=0^\circ$ onda će struja zaostajati za naponom za ugao $\varphi_I=-90^\circ$

- Za impedansu Z_L u možemo napisati:

$$\overline{Z}_L = \frac{\overline{U}_L}{\overline{I}_L} = \frac{U_L \angle 0^\circ}{I_L \angle -90^\circ} = \frac{U_L}{I_L} \angle 90^\circ$$
$$\overline{Z}_L = \omega L \angle 90^\circ = j\omega L = jX_L$$

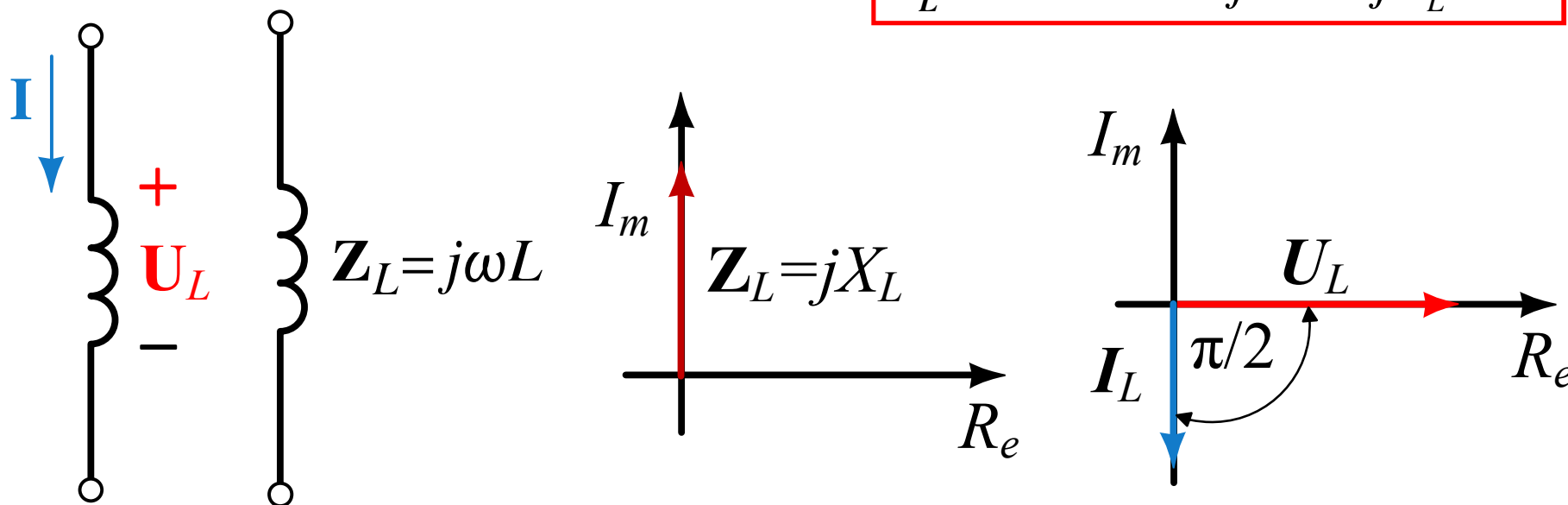

Predstavljanje kondenzatora C kao impedanse

- Kod kondenzatora C, struja I_C prednjači naponu U_C kondenzatora za ugao $\theta=90^\circ$
- Ako pretpostavimo da napon kondenzator U_C ima početni ugao $\varphi_U=0^\circ$ onda će struja I_C prednjačiti za naponom za ugao $\varphi_I=90^\circ$

- Za impedansu Z_C u možemo napisati:

$$\overline{Z_C} = \frac{\overline{U_C}}{\overline{I_C}} = \frac{U_C \angle 0^\circ}{I_C \angle 90^\circ} = \frac{U_C}{I_C} \angle -90^\circ$$

$$\overline{Z_C} = \frac{1}{\omega C} \angle -90^\circ = -j \frac{1}{\omega C} = -jX_C$$

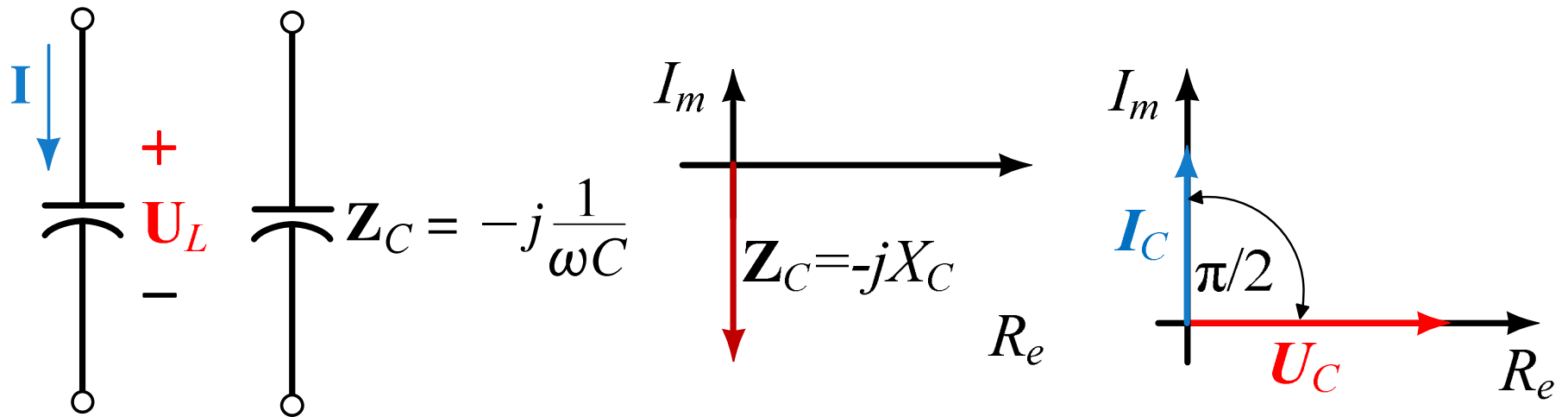

Zavojnica L u kolu naizmjenične struje

Primjer:

EXAMPLE 16–16 Consider again Example 16–12. Given $v_L = 100 \sin(400t + 70^\circ)$ and $L = 0.2$ H, determine i_L using the impedance concept.

Solution See Figure 16–40.

$$\mathbf{V}_L = 70.7 \text{ V} \angle 70^\circ \quad \text{and} \quad \omega = 400 \text{ rad/s}$$

$$\mathbf{Z}_L = j\omega L = j(400)(0.2) = j80 \ \Omega$$

$$\mathbf{I}_L = \frac{\mathbf{V}_L}{\mathbf{Z}_L} = \frac{70.7 \angle 70^\circ}{j80} = \frac{70.7 \angle 70^\circ}{80 \angle 90^\circ} = 0.884 \text{ A} \angle -20^\circ$$

In the time domain, $i_L = \sqrt{2}(0.884) \sin(400t - 20^\circ) = 1.25 \sin(400t - 20^\circ)$ A, which agrees with our previous solution.

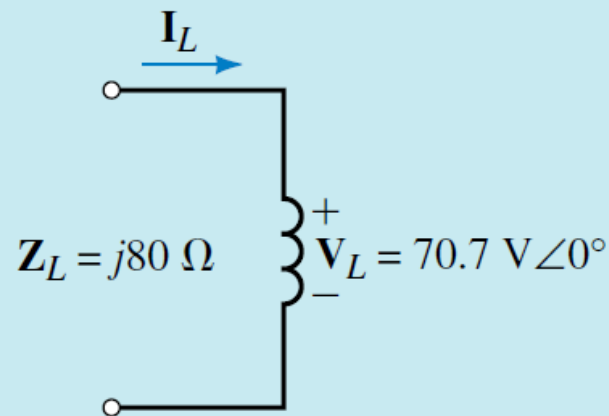

FIGURE 16–40

Kondenzator C u kolu naizmjenične struje

Primjer: **EXAMPLE 16–17** Given $v_C = 100 \sin(\omega t - 40^\circ)$, $f = 1000$ Hz, and $C = 10 \mu\text{F}$, determine i_C in Figure 16–42.

Solution

$$\omega = 2\pi f = 2\pi(1000 \text{ Hz}) = 6283 \text{ rads/s}$$

$$\mathbf{V}_C = 70.7 \text{ V} \angle -40^\circ$$

$$\mathbf{Z}_C = -j \frac{1}{\omega C} = -j \left(\frac{1}{6283 \times 10 \times 10^{-6}} \right) = -j15.92 \Omega.$$

$$\mathbf{I}_C = \frac{\mathbf{V}_C}{\mathbf{Z}_C} = \frac{70.7 \angle -40^\circ}{-j15.92} = \frac{70.7 \angle -40^\circ}{15.92 \angle -90^\circ} = 4.442 \text{ A} \angle 50^\circ$$

In the time domain, $i_C = \sqrt{2}(4.442) \sin(6283t + 50^\circ) = 6.28 \sin(6283t + 50^\circ)$ A, which agrees with our previous solution, in Example 16–14.

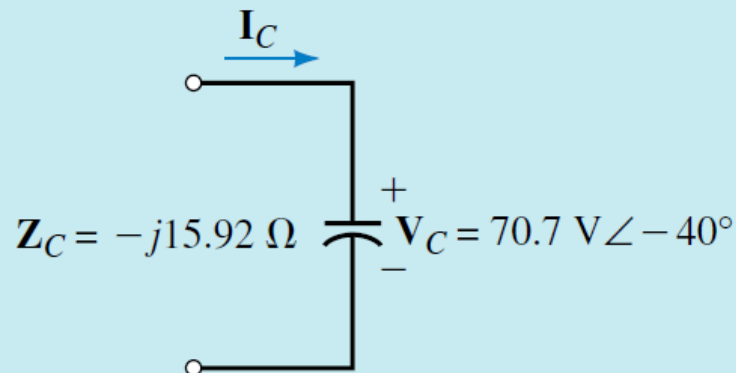

FIGURE 16–42

Zavojnica L u kolu naizmjenične struje

Primjer:

1. If $\mathbf{I}_L = 5 \text{ mA} \angle -60^\circ$, $L = 2 \text{ mH}$, and $f = 10 \text{ kHz}$, what is \mathbf{V}_L ?
2. A capacitor has a reactance of 50Ω at 1200 Hz . If $v_C = 80 \sin 800t \text{ V}$, what is i_C ?

Answers:

1. $628 \text{ mV} \angle 30^\circ$
2. $0.170 \sin(800t + 90^\circ) \text{ A}$

Serijsko RL kolo

- U serijskom kolu struja je zajednička za oba elementa. Neka je struja data u obliku: $\bar{I} = I \angle 0^\circ = I$

- Primjenom II Kirhofovog zakona u kompleksnom domenu dobijamo:

$$\bar{U} = \bar{U}_R + \bar{U}_L; \quad \bar{U} = U_R \angle 0^\circ + U_L \angle 90^\circ; \quad \bar{U} = U_R + jU_L$$

$$U = \sqrt{U_R^2 + U_L^2}$$

- Ugao θ i amplituda napona U može se dobiti iz izraza:

$$\theta = \arctg \frac{U_L}{U_R}$$

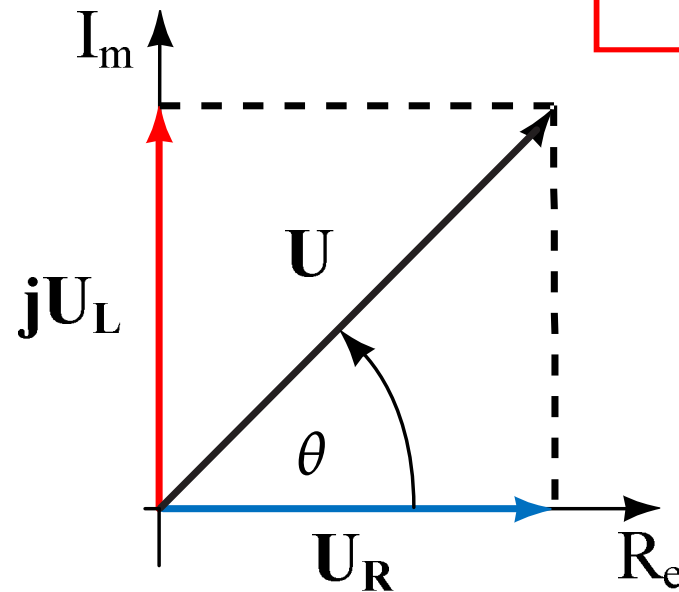
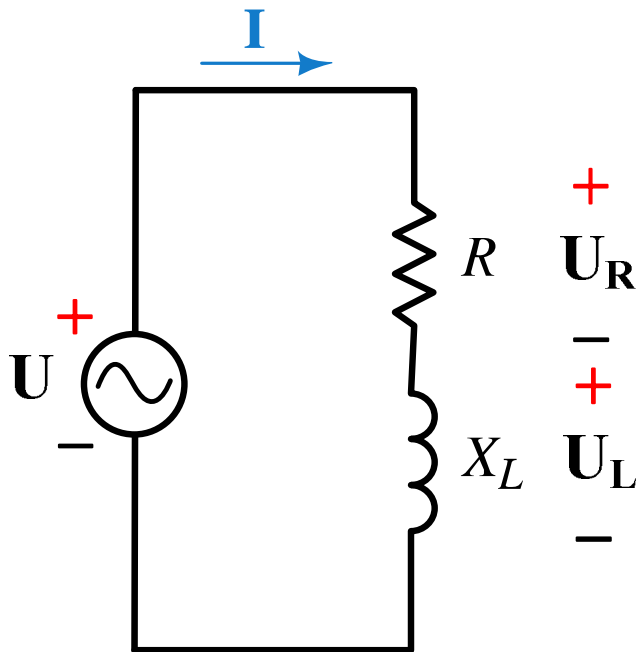

Serijsko RL kolo

- Padovi napona na elementima R i L dati su sa: $\overline{U}_R = \overline{I} \cdot \overline{Z}_R; \quad \overline{U}_L = \overline{I} \cdot \overline{Z}_L$

- Zamjenom impedansi sa: $\overline{Z}_R = R; \quad \overline{Z}_L = jX_L$

- Jednačina za napon se može napisati u obliku:

$$\overline{U} = \overline{I} \cdot R + j\overline{I} \cdot X_L = \overline{I} \cdot (R + jX_L) \Rightarrow \overline{U} = \overline{I} \cdot \overline{Z} \quad \overline{Z} = R + jX_L$$

- Ugao θ i moduo impedanse Z može se dobiti iz izraza:

$$Z = \sqrt{R^2 + X_L^2}$$

$$R = Z \cdot \cos \theta$$

$$\theta = \arctg \frac{X_L}{R}$$

$$X_L = Z \cdot \sin \theta$$

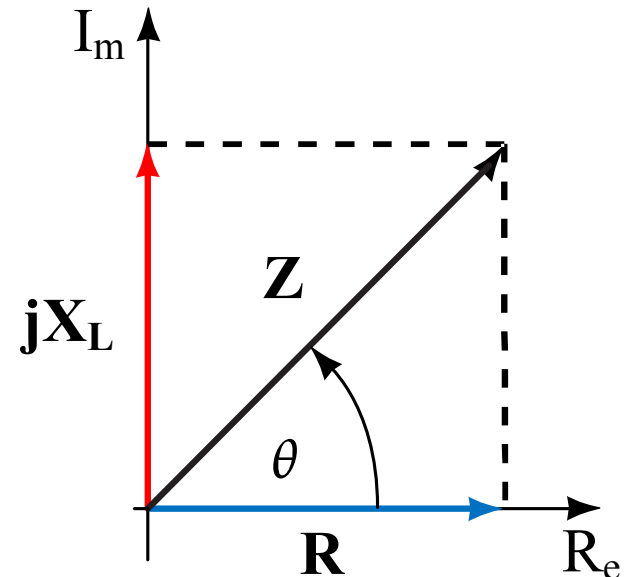

Serijsko RC kolo

- U serijskom kolu struja je zajednička za oba elementa. Neka je struja data u obliku: $\bar{I} = I \angle 0^\circ = I$
- Primjenom II Kirhofovog zakona u kompleksnom domenu dobijamo:

$$\bar{U} = \bar{U}_R + \bar{U}_C; \quad \bar{U} = U_R \angle 0^\circ + U_C \angle -90^\circ; \quad \bar{U} = U_R - jU_C$$

$$U = \sqrt{U_R^2 + U_C^2}$$

- Ugao θ i amplituda napona U može se dobiti iz izraza:

$$\theta = \arctg \frac{U_C}{U_R}$$

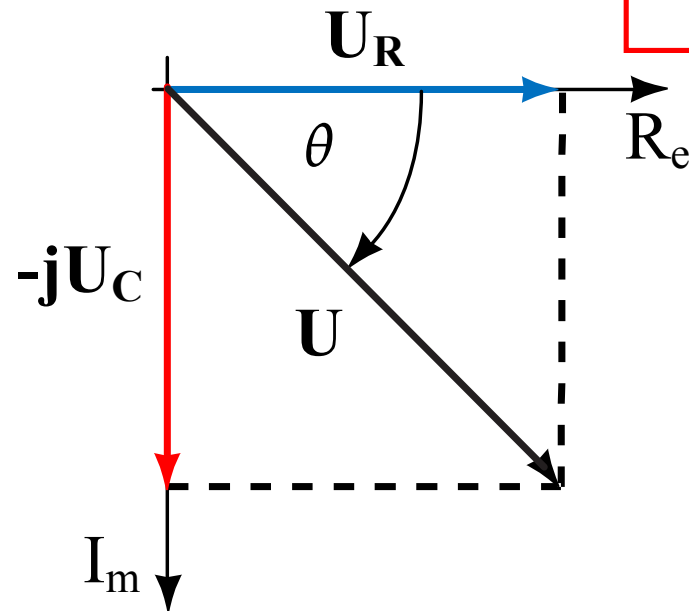
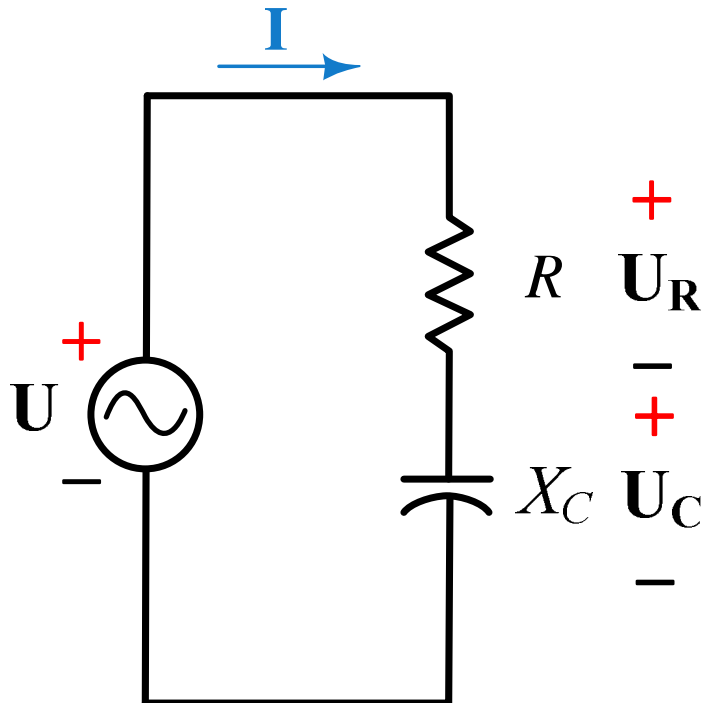

Serijsko RC kolo

- Padovi napona na elementima R i C dati su sa: $\overline{U}_R = \overline{I} \cdot \overline{Z}_R; \quad \overline{U}_C = \overline{I} \cdot \overline{Z}_C$

- Zamjenom impedansi sa: $\overline{Z}_R = R; \quad \overline{Z}_C = -jX_C$

- Jednačina za napon se može napisati u obliku:

$$\overline{U} = \overline{I} \cdot R - j\overline{I} \cdot X_C = \overline{I} \cdot (R - jX_C) \Rightarrow \overline{U} = \overline{I} \cdot \overline{Z} \quad \overline{Z} = R - jX_C$$

- Ugao θ i moduo impedanse Z može se dobiti iz izraza:

$$Z = \sqrt{R^2 + X_C^2} \quad R = Z \cdot \cos \theta$$

$$\theta = \arctg \frac{X_C}{R} \quad X_C = Z \cdot \sin \theta$$

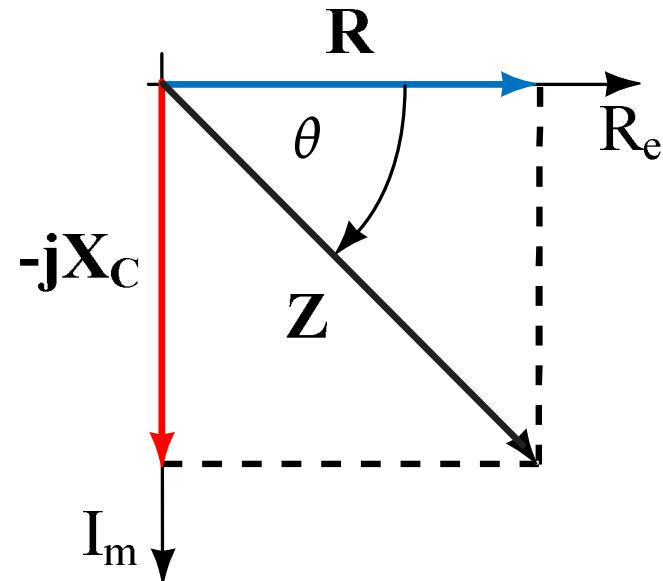

Serijsko RLC kolo

- U serijskom kolu struja je zajednička za oba elementa. Neka je struja data u obliku: $\bar{I} = I \angle 0^\circ = I$

- Primjenom II Kirhofovog zakona u kompleksnom domenu dobijamo:

$$\bar{U} = \bar{U}_R + \bar{U}_L + \bar{U}_C; \quad \bar{U} = U_R \angle 0^\circ + U_L \angle 90^\circ + U_C \angle -90^\circ;$$
$$\bar{U} = U_R + jU_L - jU_C \Rightarrow \bar{U} = U_R + j(U_L - U_C)$$

- Ugao θ i amplituda napona U može se dobiti iz izraza:

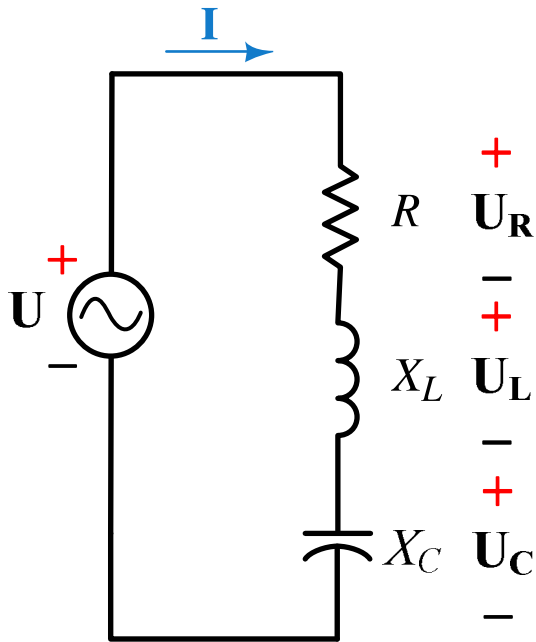

$$U = \sqrt{U_R^2 + (U_L - U_C)^2}$$

$$\theta = \arctg \frac{U_L - U_C}{U_R}$$

Serijsko RLC kolo

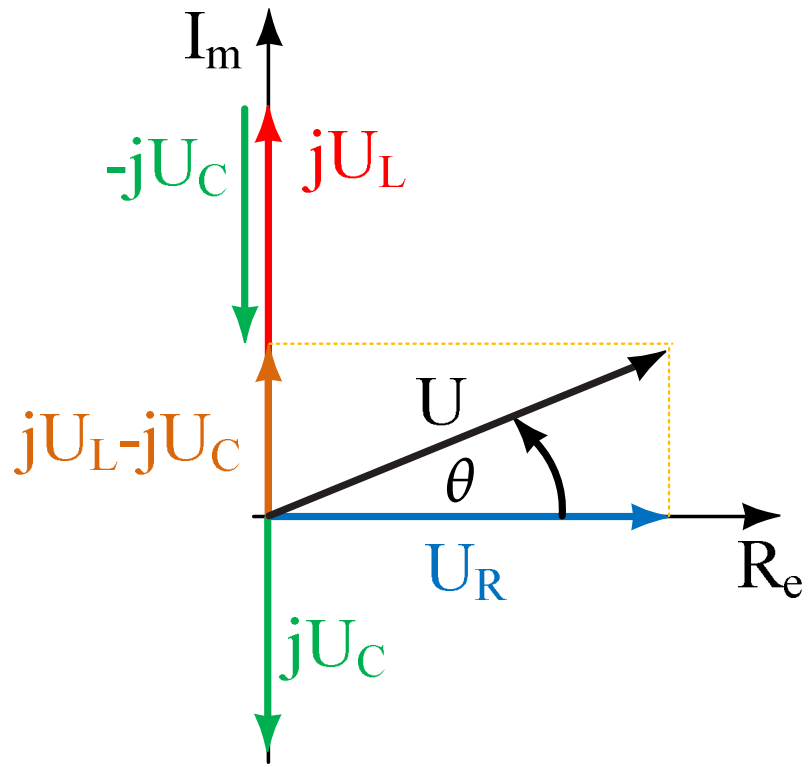

$$U_L > U_C$$

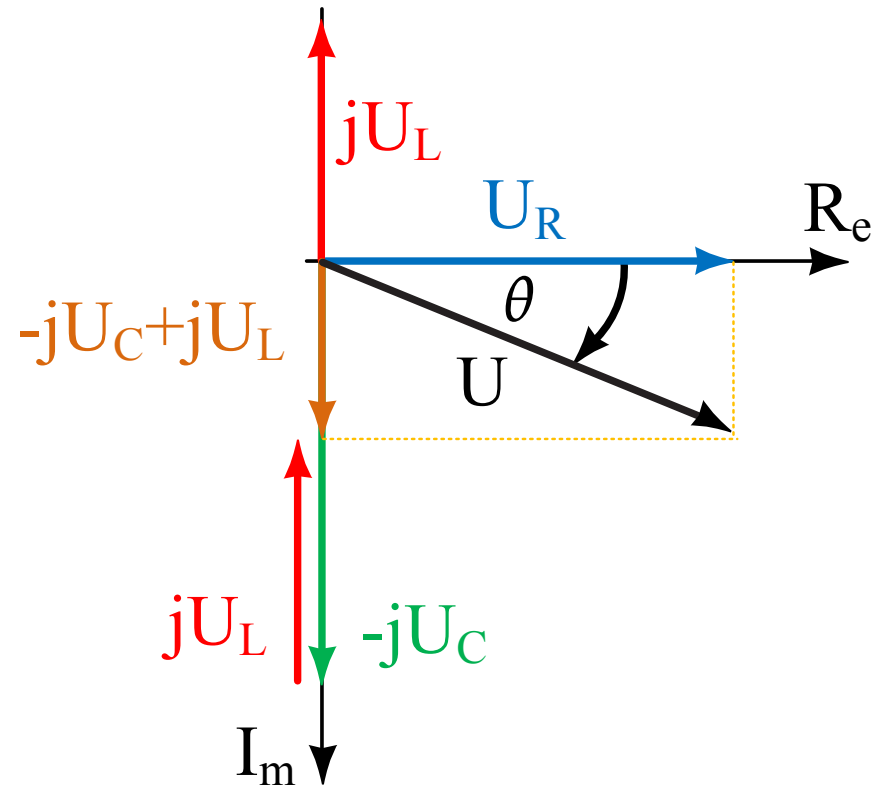

$$U_L < U_C$$

Serijsko RLC kolo

- Padovi napona na elementima R i C dati su sa:

$$\overline{U}_R = \overline{I} \cdot \overline{Z}_R; \quad \overline{U}_L = \overline{I} \cdot \overline{Z}_L; \quad \overline{U}_C = \overline{I} \cdot \overline{Z}_C;$$

- Zamjenom impedansi sa:

$$\overline{Z}_R = R; \quad \overline{Z}_L = jX_L; \quad \overline{Z}_C = -jX_C$$

- Jednačina za napon se može napisati u obliku:

$$\overline{U} = \overline{I} \cdot R + j\overline{I} \cdot X_L - j\overline{I} \cdot X_C = \overline{I} \cdot (R + jX_L - jX_C)$$

$$\overline{U} = \overline{I} \cdot [R + j(X_L - X_C)] = \overline{I} \cdot (R \pm jX);$$

$$\overline{Z} = R \pm jX; \quad \overline{U} = \overline{I} \cdot \overline{Z}$$

- Ugao θ i moduo impedanse Z može se dobiti iz izraza:

$$Z = \sqrt{R^2 + (X_L - X_C)^2}$$

$$\theta = \arctg \frac{X_L - X_C}{R}$$

$$R = Z \cdot \cos \theta$$

$$X = Z \cdot \sin \theta$$

Serijsko RLC kolo

Primjer:

EXAMPLE 18–5 Consider the network of Figure 18–20.

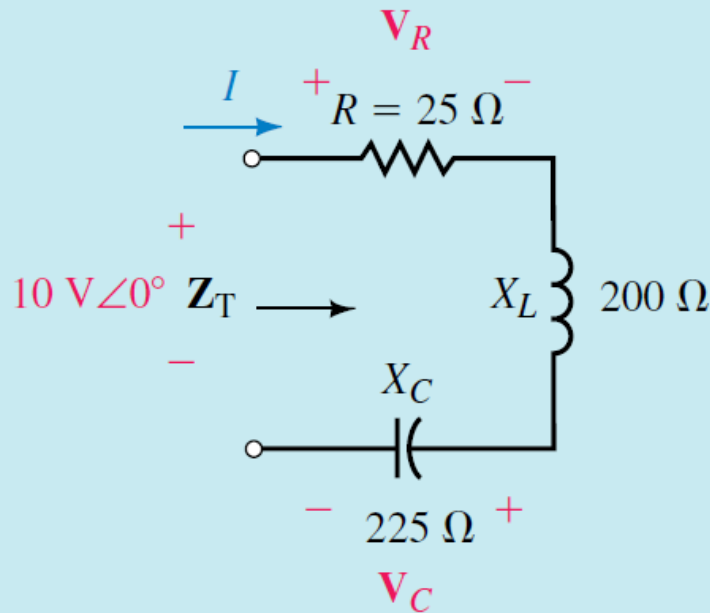

FIGURE 18–20

- Find Z_T .
- Sketch the impedance diagram for the network and indicate whether the total impedance of the circuit is inductive, capacitive, or resistive.
- Use Ohm's law to determine I , V_R , and V_C .

Serijsko RLC kolo

Primjer:

Solution

a. The total impedance is the vector sum

$$\begin{aligned} \mathbf{Z}_T &= 25 \Omega + j200 \Omega + (-j225 \Omega) \\ &= 25 \Omega - j25 \Omega \\ &= 35.36 \Omega \angle -45^\circ \end{aligned}$$

b. The corresponding impedance diagram is shown in Figure 18–21.

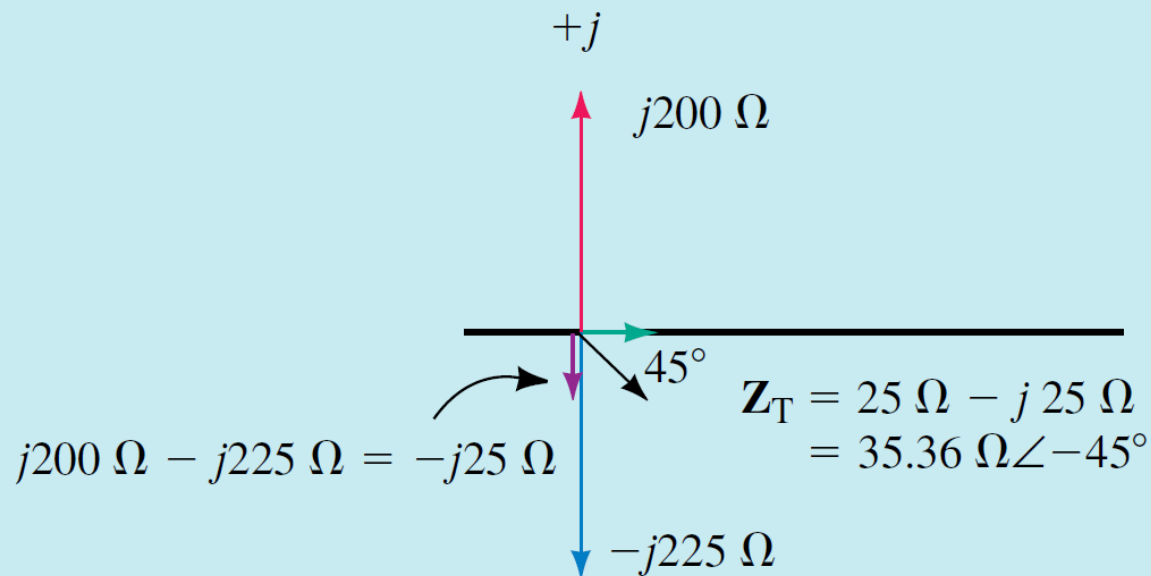

Serijsko RLC kolo

Primjer:

Because the total impedance has a negative reactance term ($-j25 \Omega$), \mathbf{Z}_T is capacitive.

$$c. \quad \mathbf{I} = \frac{10 \text{ V} \angle 0^\circ}{35.36 \Omega \angle -45^\circ} = 0.283 \text{ A} \angle 45^\circ$$

$$\mathbf{V}_R = (282.8 \text{ mA} \angle 45^\circ)(25 \Omega \angle 0^\circ) = 7.07 \text{ V} \angle 45^\circ$$

$$\mathbf{V}_C = (282.8 \text{ mA} \angle 45^\circ)(225 \Omega \angle -90^\circ) = 63.6 \text{ V} \angle -45^\circ$$

Serijsko RLC kolo

Primjer:

EXAMPLE 18-6 Determine the impedance \mathbf{Z} which must be within the indicated block of Figure 18-22 if the total impedance of the network is $13 \Omega \angle 22.62^\circ$.

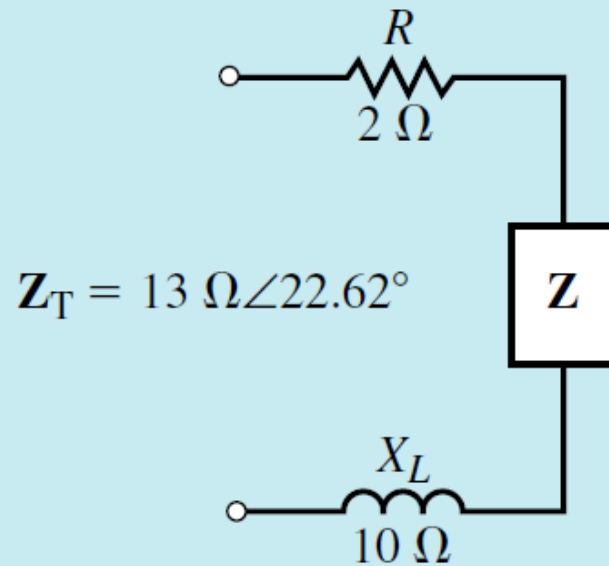

FIGURE 18-22

Serijsko RLC kolo

Primjer:

Solution Converting the total impedance from polar to rectangular form, we get

$$\mathbf{Z}_T = 13 \Omega \angle 22.62^\circ \Leftrightarrow 12 \Omega + j5 \Omega$$

Now, we know that the total impedance is determined from the summation of the individual impedance vectors, namely

$$\mathbf{Z}_T = 2 \Omega + j10 \Omega + \mathbf{Z} = 12 \Omega + j5 \Omega$$

Therefore, the impedance \mathbf{Z} is found as

$$\begin{aligned} \mathbf{Z} &= 12 \Omega + j5 \Omega - (2 \Omega + j10 \Omega) \\ &= 10 \Omega - j5 \Omega \\ &= 11.18 \Omega \angle -26.57^\circ \end{aligned}$$

Serijsko RLC kolo

Primjer:

In its most simple form, the impedance \mathbf{Z} will consist of a series combination of a $10\text{-}\Omega$ resistor and a capacitor having a reactance of $5\ \Omega$. Figure 18–23 shows the elements which may be contained within \mathbf{Z} to satisfy the given conditions.

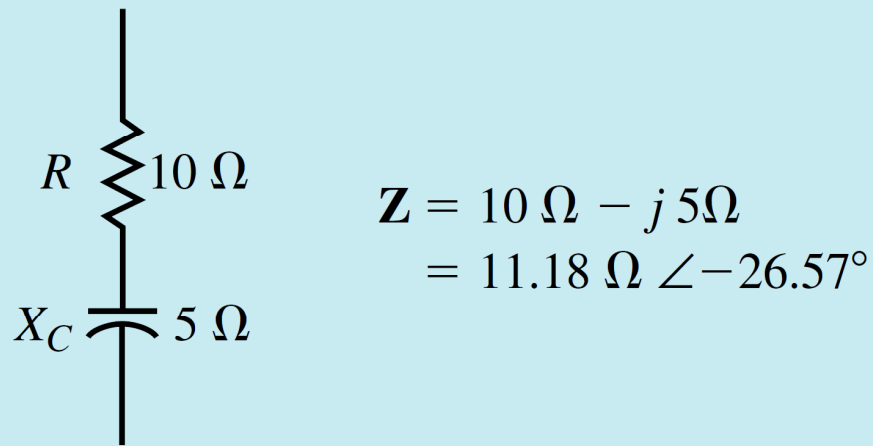

$$\begin{aligned}\mathbf{Z} &= 10\ \Omega - j5\ \Omega \\ &= 11.18\ \Omega \angle -26.57^\circ\end{aligned}$$

FIGURE 18–23

Serijsko RLC kolo

Primjer:

EXAMPLE 18-7 Find the total impedance for the network of Figure 18-24. Sketch the impedance diagram showing Z_1 , Z_2 , and Z_T .

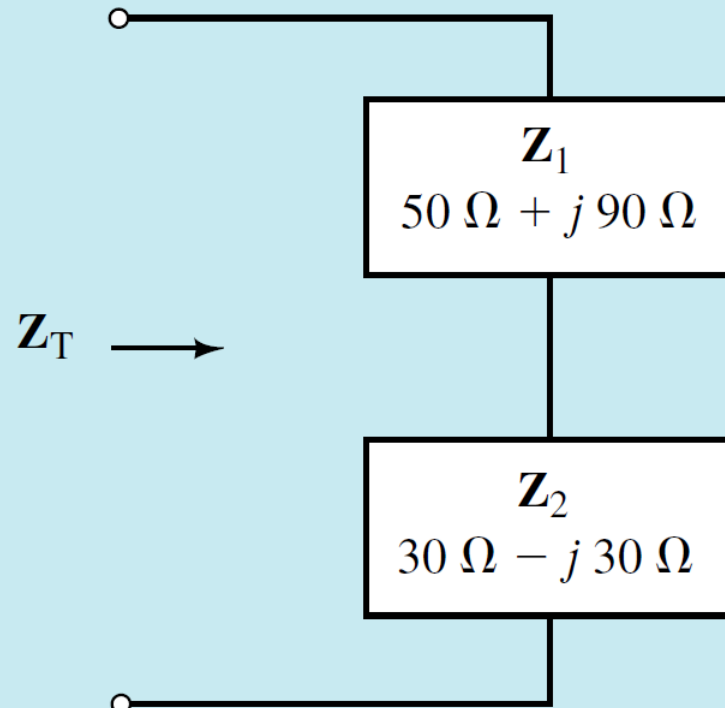

FIGURE 18-24

Serijsko RLC kolo

Primjer:

Solution:

$$\begin{aligned}\mathbf{Z}_T &= \mathbf{Z}_1 + \mathbf{Z}_2 \\ &= (50 \Omega + j90 \Omega) + (30 \Omega - j30 \Omega) \\ &= (80 \Omega + j60 \Omega) = 100 \Omega \angle 36.87^\circ\end{aligned}$$

The polar forms of the vectors \mathbf{Z}_1 and \mathbf{Z}_2 are as follows:

$$\begin{aligned}\mathbf{Z}_1 &= 50 \Omega + j90 \Omega = 102.96 \Omega \angle 60.95^\circ \\ \mathbf{Z}_2 &= 30 \Omega - j30 \Omega = 42.43 \Omega \angle -45^\circ\end{aligned}$$

The resulting impedance diagram is shown in Figure 18–25.

Serijsko RLC kolo

Primjer:

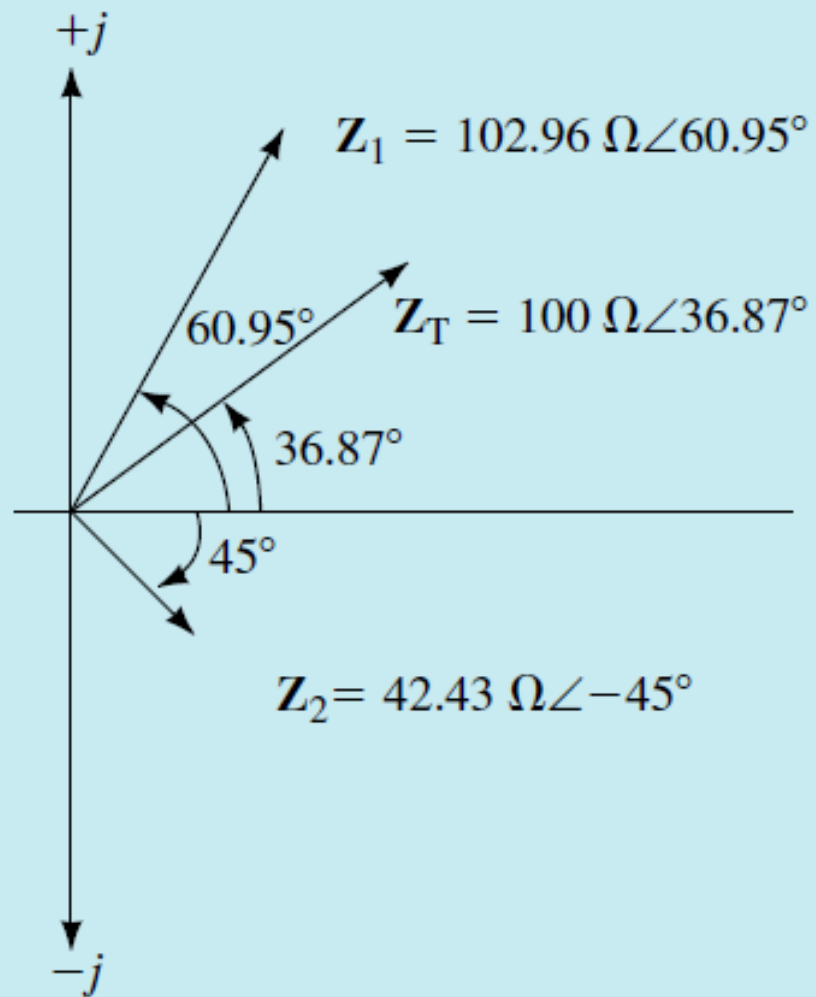

FIGURE 18-25